

Appendix J Design and Drafting Tools

AGTEK software is not intended to be a design and drafting system and it cannot match the broad design and drafting functionality of a dedicated CAD program. However, if you don't have access to a CAD program, AGTEK does include a number of design and drafting tools that can be usefully applied to various modeling and takeoff scenarios.

This exercise applies a number of these tools to the example of a base map and existing topo for a vacant parcel of land that is being considered for a small residential development around a proposed cul-de-sac street. Starting only with the base map and existing topo data (which can be manually digitized or imported from a PDF or CAD file), we develop a conceptual/preliminary design for the street and lots that results (ideally) in balanced grading volumes. The base map and topo contours are illustrated on the following page but the ***draftingtools.esw*** file containing this already-entered starting data can be downloaded from the Earthwork Software Services website (see [Appendix C](#)).

The following typical street section will also be referenced for this exercise:

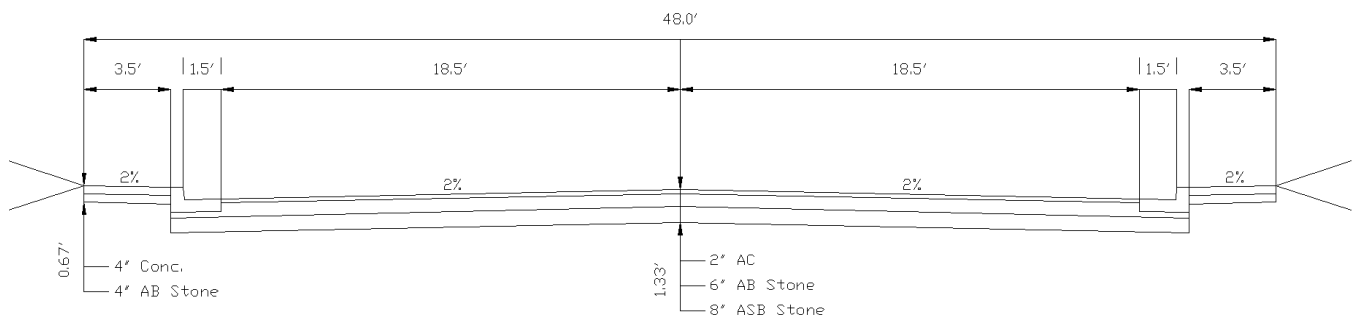

*Tip: If you do any conceptual site planning and analysis (for your own developments or as a courtesy at the request of a favored client), take a look at the additional resources linked at www.earthworksoftwareservices.com/resourcesa.htm. These resources include some interesting (and free) **analytic add-ons for Google Earth**.*