

Modeling with Vector Data Step-by-Step

Street Details, Site Location Map and Plan Abbreviations/Notes

Curb and Gutter Detail
N.T.S.

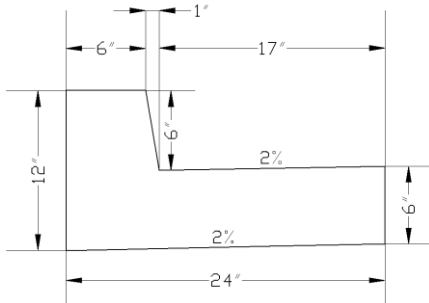

Typical Street Section
N.T.S.

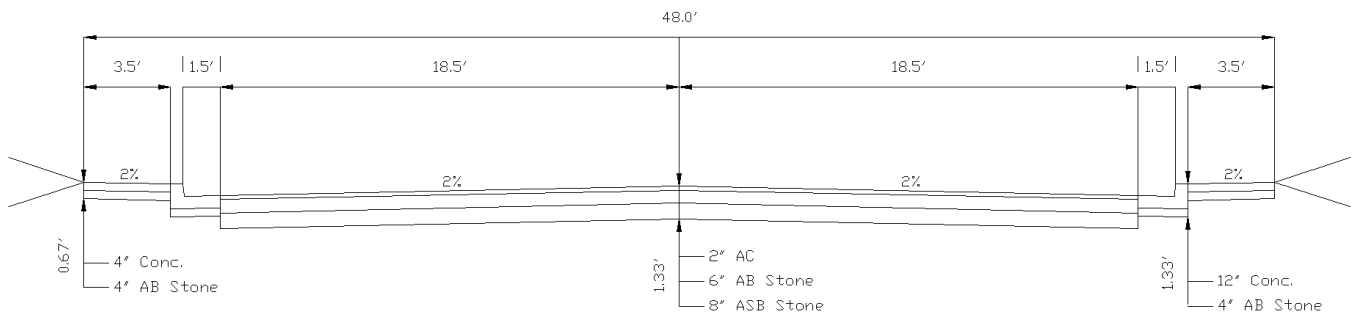

Plan Abbreviations

AB	Aggregate base	N	Northing horizontal ordinate
ASB	Aggregate subbase	NTS	Not to scale
Approx	Approximate	Pvmt	Pavement
AC	Asphaltic concrete	PL	Property line
Bot	Bottom elevation	BW	Proposed bottom of wall elevation
Bldg	Building	FF	Proposed finish floor elevation
Conc	Concrete	LS	Proposed landscape elevation
E	Easting horizontal ordinate	TC	Proposed top of curb elevation
EG	Existing grade/elevation	TW	Proposed top of wall elevation
E-TC	Existing top of curb elevation	Typ	Typical
Misc	Miscellaneous		

Notes

1. Proposed contour and spot elevations represent finished surface grade.
2. Grading contractor to strip 5" topsoil prior to grading (stockpile for 6" resread at landscape areas, offhaul balance).

**Site Location Map
(Chico, California)**

